

TRAINING ON ANTAM STANDARD CODE For TESTING OF KNAPSACK MISTERS CUM DUSTERS

PART -3 : INTRODUCTION TO PORTABLE MISTER CUM DUSTER

16 - 28 October 2016, Nanjing China

**2nd Training of Trainers on ANTAM Codes
Organized by ANTAM and CAMTC**

**AN INTRODUCTION TO PORTABLE MISTERS CUM
DUSTERS**

BY

C.W. CHAN* and J.P. DOUZALS

*** Malaysian Agricultural Research and Development
Institute**

Knapsack Mister cum Duster

Different denominations :

Knapsack Mister cum Duster

Portable Mister cum Duster

Knapsack combustion-engine-driven mistblowers/dusters (ISO)

MISTER



DUSTER



Knapsack Mister cum Duster

Portable, engine driven, mister and/or duster



Application of liquids, powders (pesticides, fertilizers) seeds broadcasting

Agriculture : Field crops

Health : Mosquito control,

Buildings: Desinsectization

Knapsack Mister cum Duster

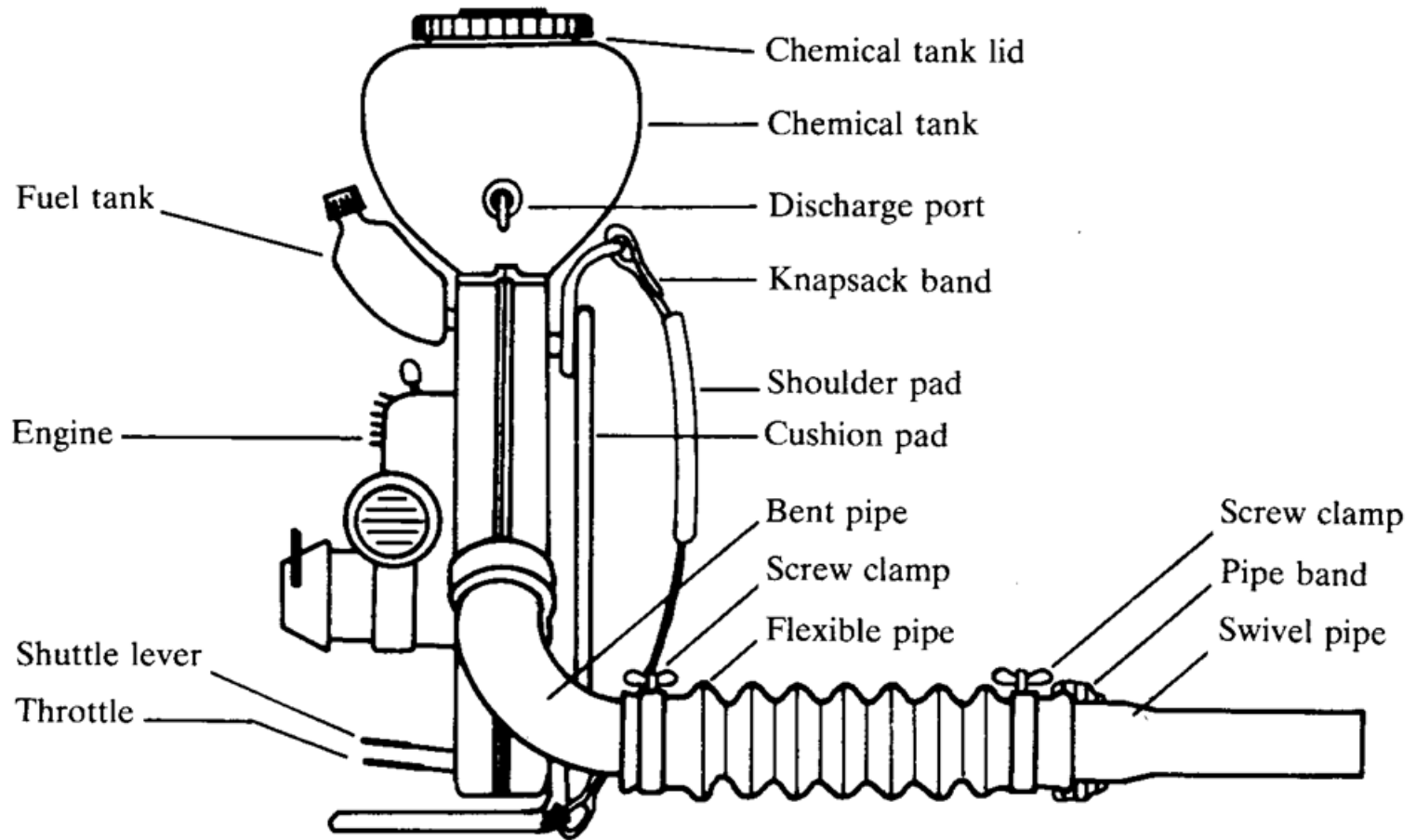

Knapsack Mister cum Duster



Knapsack Mister cum Duster



Knapsack Mister cum Duster



Maruyama MD 165DX Backpack Mist Blower

- Durable, lightweight & versatile; enable 8 hours nonstop heavy- duty application.
- Corrosion-resistant chemical tank and engine frame designed for superior durability and stability.
- One-Pull-Start with electronic ignition for accurate and quick starts with easy hand throttle system resulting in trouble-free maintenance.
- Compact engine & fan design for easy inspection & maintenance; minimum vibration and low noise for comfort during operation.
- Large and powerful blower capacity ensures wider coverage and uniform spray.
- Low fuel consumption for extended operating hours.
- Optional attached parts and nozzles are available for diversified application needs.
- Can be used as ULV spraying (with special nozzle-atomizer).

Knapsack Mister cum Duster



Maruyama MD 6080 **Backpack Motorised Duster**

- » Multi-purpose for broadcasting dust and granular pesticides, fertilizer, seeds and aquatic food; as well as misting of liquid type chemicals and fertilizers with optional accessories.
- » Light weight and compact design with minimum vibration and noise assuring comfortable operation.
- » Corrosion-resistant chemical tank is easily switchable without the use of any tools.
- » Proven engine and fan combination provides a dramatic boost in operating performance & superior durability.
- » Comfortable S-Shape carrying mesh-type straps, easily adjustable and user friendly.
- » Large and powerful turbo blower capacity. Releases large volume of air for wider area coverage with uniform spraying.
- » Throwing distance of approximately 22 meters with high precision.
- » With the use of 'Bena Pipe', the sprayer can be used to speedily control pest & disease outbreak at around 50 minutes/ha.

Knapsack Mister cum Duster



Maruyama MDJ 6026 **Backpack Motorised Mist Duster**

- » Multi-purpose for broadcasting of dust and granular pesticides, fertilisers, seeds and aquatic food as well as misting of liquid type chemicals and fertilisers which are optional accessories.
- » Lightweight and compact design with minimum vibration, assuring comfortable operation.
- » Corrosion-resistant chemical tank is easily switchable without the use of any tools.
- » MARUYAMA proven engine and fan combination provides a dramatic boost in operating performance & superior durability.
- » Comfortable carrying straps that are easily adjustable and user friendly.
- » Large and powerful blower capacity ensures wider area coverage with uniform spraying.
- » Throwing distance of approximately 12 meters with high precision.
- » With the use of 'Bena Pipe', the sprayer can be used to control pest & disease outbreak with high precision and fast results (50 minutes/ha).

Knapsack Mister cum Duster



MD6026	
Specifications	
48.6 cc	
12.5 kg	
26 Lt tank	
Standard application for dry chemical	
Maximum range: 12m horizontal – vertical	
8m	



MD180DX-30 Specifications

Dimensions(LxWxH)	410/475/720 mm
Dry Weight	11.7 kg
Engine	KAWASAKI TK65 (64.7cc)
Displacement	2.9 kw
Recoil Starter System	Standard
Spark Plug	NGK BPMR7A
Ignition System	C.D.I.
Chemical Tank	30 L
Max. Discharge Volume	3.8L/min
Mist Reach Distance (Horizontal)	14 m
Mist Reach Distance (Vertide)	11 m
Vibration Level (Grip Handle) *1	1.35 m/s ²
Guaranteed Sound Power Level*2	74.7 dB(A)

*1 Vibration level on the throttle handle measured according to ANSI B175.2

*2 Guaranteed sound power level EC directive 2000/14/EC, ISO11094

Knapsack Mister cum Duster

Item	MIST DUSTER
Model	3WF-3A(20L/26L)
Motor type	1E40F-3
Max.power	2.13kw/ 7500r/min
Tank capacity	20L / 26L
Spraying range	≥12m
Weight	11.5 / 12kgs
Size	53×44×80cm



MODEL :	3WF-700G
TANK CAPACITY (L) :	20
RANGE (m) :	>16
MATCHED ENGINE:	1E47F
DISPLACEMENT(cc):	59.2
STANDARD POWER(kw/r/min):	2.65/7500
FORM OF CARBURETOR:	CIRCULATION TYPE
MIXED FUEL RATIO:	25:1
FUEL TANK CAPACITY(L):	1.8
WEIGHT(N.W./G.W.)(kg):	12.5/16.5
PACKING MEASUREMENT(mm):	500*440*780

Knapsack Mister cum Duster

	ASPEE MB/2
Power	1.2 HP
Type	2 stroke
Tank capacity	11.5 L
Misting range	-
Misting rate	-
Air speed	62 m/s
Air volume	8 m ³ /min
Weight	11,5 kg



Knapsack Mister cum Duster

Fig. 1

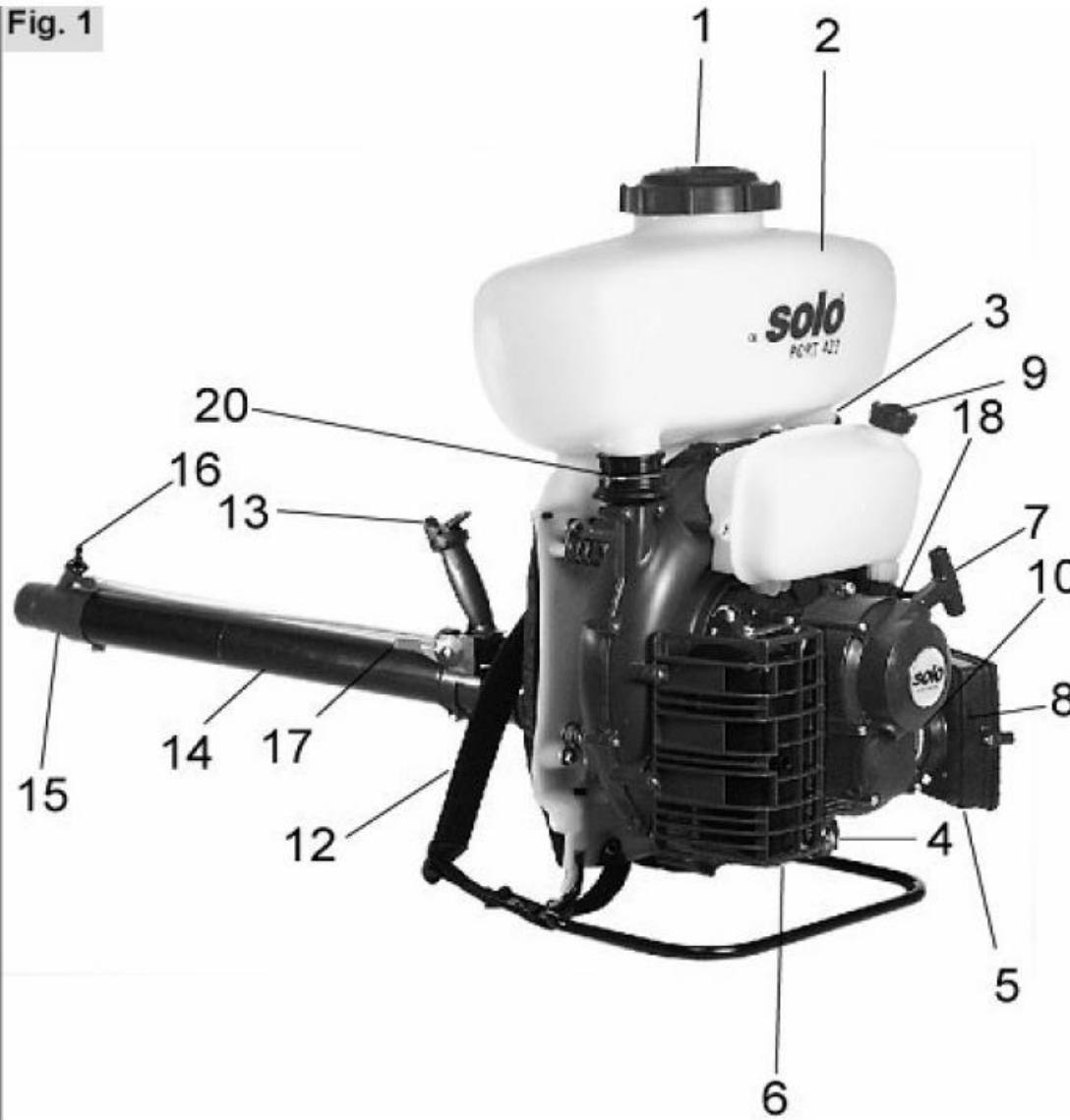

1. Tank lid / Filler basket with filter
2. Formula tank
3. Formula outlet
4. Spark plug
5. Carburetor
6. Muffler
7. Starter handle
8. Air filter
9. Fuel tank cap
10. Fuel tank cap
12. Shoulder strap – quick coupling
13. Liquid tap
14. Spray tube
15. Spray nozzle
16. Dosage sleeve
17. Throttle lever
18. Fuel tap
20. Tank ventilation

Knapsack Mister cum Duster

FIG. 2: MODEL 18539 BAK-PAK® POWER MIST DUSTER

